



PACIFIC[™]
F L O O R C A R E

PURPOSE BUILT.[™]

PARTS & OPERATING MANUAL

FM-17DS & FM-20DS FLOOR MACHINES

PLEASE READ THIS BOOK

This operator's book has important information for the use and safe operation of this machine. Read this book carefully before using the machine. Keep this book and tell all operators to read the book. If you do not follow the instructions, you can cause an injury or damage equipment, furniture or buildings.

For new books, please download your copy from our website www.pacificfloorcare.com or write to:

Pacific Floorcare
2259 S. Sheridan Drive
Muskegon, MI 49442-6252

Carefully inspect all components to ensure that there is no concealed freight damage. If such damage is discovered, file a "CONCEALED DAMAGE REPORT" immediately with the delivering carrier.

The contents of this manual are based on the latest product information available at the time of publication. Pacific reserves the right to make changes or improvements without notice.

**Thank you for purchasing a Pacific Floorcare product. Warranty registration will allow us to better serve you over the lifetime of the product. For quick and easy registration, go to:
www.pacificfloorcare.com/Register Product.**

IMPORTANT SAFETY INSTRUCTIONS

To ensure the safe operation of this machine, you must read and understand all warnings and instructions in this book. If you do not understand, ask your supervisor.

READ ALL INSTRUCTIONS BEFORE USING THIS MACHINE

WARNING: To reduce the risk of fire, electric shock, or injury:

1. You must be trained to operate this machine. This machine is to be operated for its intended use only.
2. Do not operate this machine unless it is completely assembled.
3. Always use a three-wire electrical system connected to the electrical ground. For maximum protection against electrical shock, use a circuit that is protected by a ground fault circuit interrupter. Consult your electrical contractor.
4. To prevent electric shock, always remove the electrical plug from the electrical outlet before doing any repairs or maintenance and when leaving the machine unattended.
5. To prevent electric shock, keep the machine surface dry. Do not subject to rain. Store the machine in a dry building area. Clean the machine with a dry cloth only.
6. Machines can cause an explosion when near flammable materials and vapors. Do not use this machine with or near fuels, grain dust, solvents, thinners, or other flammable materials. Do not use flammables to clean this machine.
7. A qualified or authorized person must do maintenance and repairs.
8. To prevent damage to the power cord, do not move this machine over the power cord. Always lift the power cord over the machine. Do not pull or carry cord, use cord as a handle, close a door on cord, or pull cord around sharp edges or corners. Keep cord away from heated surfaces.
9. Do not use with damaged cord or plug. If the machine is not working as it should, has been dropped, damaged, left outdoors, or dropped into water, return it to a service center.

Grounding Instructions

This machine must be grounded. If it should malfunction or break down, grounding provides a path of least resistance for electric current to reduce the risk of electric shock. This machine is equipped with a cord having an equipment-grounding conductor and grounding plug. The plug must be inserted into an appropriate outlet that is properly installed and grounded in accordance with all local codes and ordinances.

WARNING - Improper connection of the equipment-grounding conductor can result in a risk of electric shock. Check with a qualified electrician or service person if you are in doubt as to whether the outlet is properly grounded. Do not modify the plug provided with the machine. If it will not fit the outlet, have a proper outlet installed by a qualified electrician.

This machine is for use on a nominal 120-volt circuit, and has a grounded plug that looks like the plug illustrated in figure A. A temporary adapter that looks like the adapter illustrated in figures B and C may be used to connect this plug to a 2-pole receptacle as shown in figure B if a properly grounded outlet is not available. The temporary adapter should be used only until a properly grounded outlet (figure A) can be installed by a qualified electrician. The green colored rigid ear, lug, or the like extending from the adapter must be connected to a permanent ground such as a properly grounded outlet box cover. Whenever the adapter is used, it must be held in place by a metal screw.

NOTE: In Canada, the use of a temporary adapter is not permitted by the Canadian Electrical Code

EXTENSION CORDS

Use only three-wire 12/3 or larger gauge approved extension cords that have three-prong grounding type plugs and three-pole receptacles that accept the appliance's plug. Replace or repair any damaged cords or plugs.

When servicing, refer to authorized person only. Use only identical replacement parts.

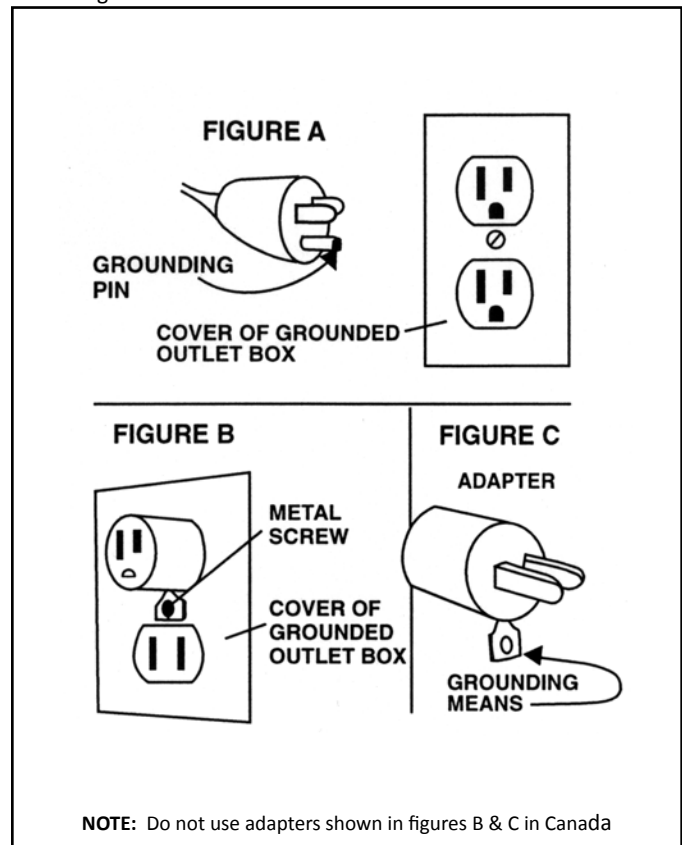

OPERATING PROCEDURES

WARNING! For the safe operation of this machine follow the instructions given in this manual and the training given by your supervisor. Failure to do so can result in personal injury and/or damage to machine and property!

DO NOT OPERATE MACHINE IN AN EXPLOSIVE ENVIRONMENT!

This machine is intended for commercial use.

PREPARATION

To prepare the machine for operation, make sure it is of correct voltage and properly assembled.

Your new floor machine operates in the normal side to side motion of a conventional single disc machine. Be prepared before starting by removing all obstructions or other obstacles in the area to be cleaned. Check the proper application recommendations and procedures found on the label of your cleaning or finish container. IF IN DOUBT, CALL YOUR SUPERVISOR .

WARNING! NEVER USE THIS MACHINE WITH FLAMMABLE OR EXPLOSIVE MATERIAL!

For Scrubbing or Polishing: Select the correct floor pad or brush (your supplier can help you). If in doubt, ask your supervisor.

NEVER OPERATE THE MACHINE WITHOUT THE FLOOR PAD OR BRUSH INSTALLED!

To properly attach the brush, UNPLUG THE FLOOR MACHINE, place the handle in the vertical position, then tilt the machine back until the handle rests on the floor. Straddle the handle, facing the motor, and grasp the brush with the block toward you. Place the brush or pad clutch plate over the three lugs on the motor drive adapter. Twist the brush right to lock it into position. To remove the brush, UNPLUG THE MACHINE and follow the same procedure as above, but by twisting the brush off with a firm jerk to the left. Remove the brush or pad driver when the machine is not in use. This will help prevent brush damage and reduce wobble problems.

DUAL SPEED CONTROL: A rocker switch is located on the motor drip cover. Press the switch in on the side labeled LOW for 175 RPM pad speed or to HIGH for 300 RPM pad speed.

OPERATION

Plug the machine's power cable into a properly grounded outlet (see Safety Instructions). Next, adjust the handle height to a comfortable position.

Pull out on the "Watch Dog" Safety Lock button and start the machine by depressing either the left or right switch levers.

Both hands should be placed on the handle when the machine is in operation. The machine will glide sideways over the floor by a slight raising and lowering of the handle. Raise the handle slightly to go to the right. Lower the handle slightly to go left. **Releasing the switch lever stops the machine.**

For Spray Buffing: A diluted spray material of about one part water to one part solution is recommended. Heavier spray buff solutions will bog down the machine, load up the pad and adversely affect the machine's efficiency.

MAINTENANCE

AFTER EACH USE: Store the machine in a clean dry area. Wipe the entire machine and cord down with a clean cloth. Remove the pad or brush and clean thoroughly. Wrap the machine's electrical cord onto the handles and the cord hook provided. CHECK the cord and plug for nicks, cuts or damage. Report these to your supervisor for correction.

WARNING! Always disconnect the machine's electrical plug from the electrical outlet before performing any service, maintenance, pad changing or inspection of the machine.

MOTOR: The motor is lubricated for life under normal use. No oiling or greasing is necessary. However, if the machine is used in dusty areas or is used for spray buffing, the motor should be cleaned. Blowing the motor out with compressed air or with the exhaust from a vacuum is suggested. Keeping the motor clean will allow the clear passage of air for ventilation and prevent overheating. If you have any questions regarding the maintenance of your floor machine, ASK YOUR SUPERVISOR.

CARBON BRUSH INSPECTION: Long life 3000-hour carbon brushes are installed in the motor. The machine is also equipped with a carbon brush wear indicator to signal when a carbon brush change is required.

FM-17DS & FM-20DS FLOOR MACHINES

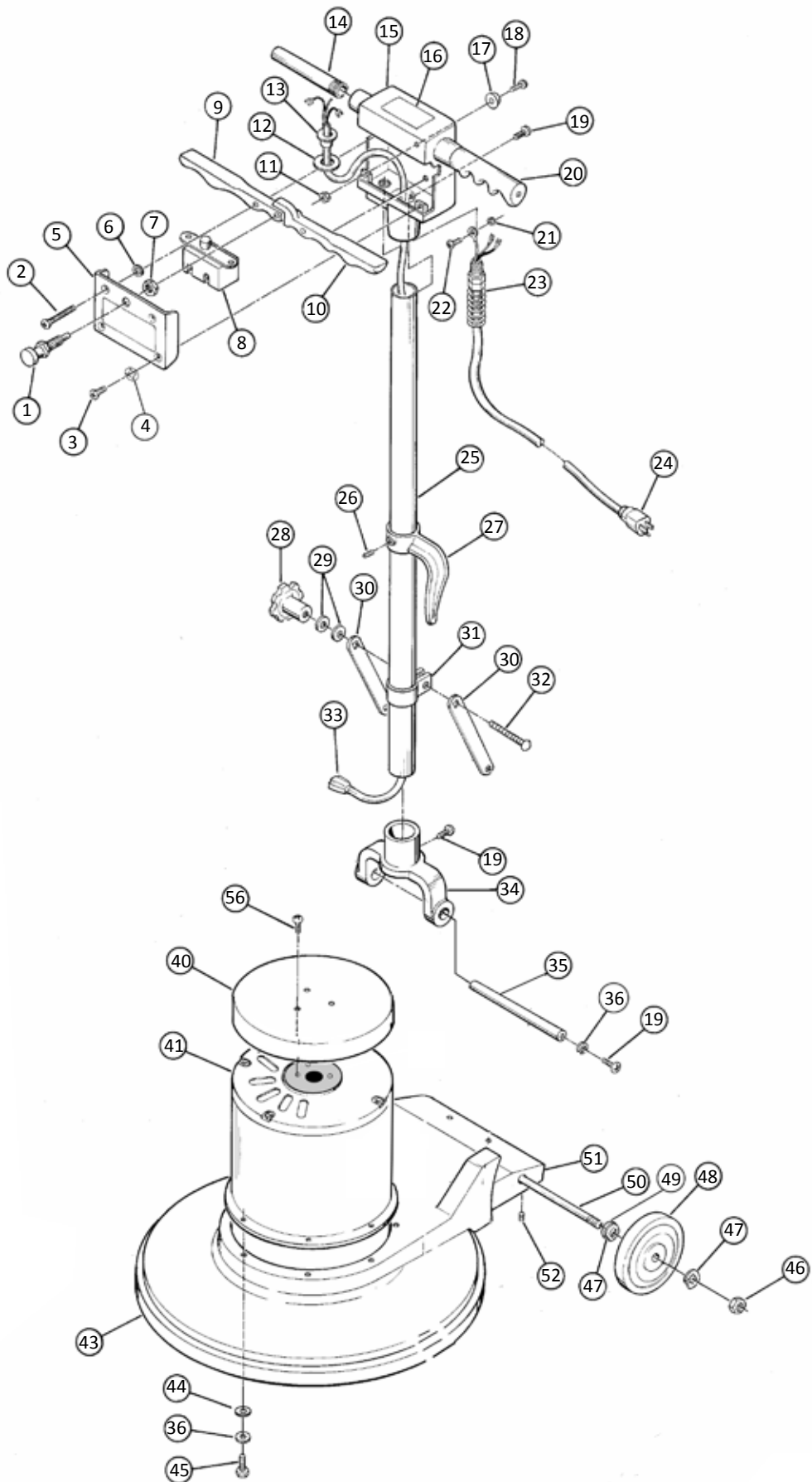

ITEM	PART NO.	DESCRIPTION	QTY.
1	504810	Interlock Asm.-Switch	1
2	962011	Screw, 10-32 x 3/4 Oval Hd.	2
3	962002	Screw, 10-32 x 1/2 Oval Hd.	2
4	980018	Washer, #10 Countersunk	1
5	486407	Switch Cover Plate	1
6	509821	Washer, Rubber	2
7	920005	Nut, 3/8-24 Hex	1
8	485002	Switch (Non-UL Approved Units)	1
	508020	Switch (UL Approved Units Only)	1
9	505120	Lever, Switch Right	1
10	505121	Lever, Switch Left	1
11	920001	Nut, 10-32 Elastic Stop	1
12	509830	Washer, Handle Tube	1
13	503320	Flange, Strain Relief	1
14	505720	Handle Nipple	2
15	-->	Use 483921 Handle Assm.	1
16	515150	Warning Label	1
17	501210	Bumper, Handle	1
18	962003	Screw, 10-32 x 3/4 Pan Hd.	1
19	962006	Screw, 1/4-20 x 1/2 Pan Hd.	6
20	503711	Handle Grip, Grey	2
20	501501	Cap, Protective End (Blue)	2
21	980015	Washer, #10 Shakeproof	2
22	962015	Screw, 10-32 x 3/8 Pan Hd.	2
23	508520	Strain Relief-Complete	1
23	502020	Strain Relief-Brass Clamp	1
24	502422	Cord Asm.-50 ft. Yellow	1

ITEM	PART NO.	DESCRIPTION	QTY.
25	509082	Handle Tube	1
26	962005	Screw, 1/4-20 x 3/8 Allen	1
27	504420	Cord Hook	1
28	505010	Knob, Turn	1
29	980007	Washer, 5/16 Flat	2
30	500840	Brace	2
31	502021	Clamp, Handle	1
32	962009	Bolt, 5/16-18 x 2 1/2 Carriage	1
33	908008	Handle Cord Assembly	1
34	509920C	Yoke, Handle	1
35	507480	Shaft, Handle Pivot	1
36	980002	Washer, 1/4 Lock	6
40	502397	Cover, Motor, Dual Speed	1
41	See Page 6	Motor & Gear Box Assembly	1
43	481202	Bumper, 17"	1
	481203	Bumper, 20"	1
44	980004	Washer, 1/4 Flat	4
45	962010	Screw, 1/4-20 x 1 HH	4
46	W502D	Nut, 1/2-13 Hex	2
47	980005	Washer, Wave	2
48	509781	Wheel, 5"	2
49	509820	Washer, Fiber	2
50	487702	Wheel Axle	1
51	483226	Base 17"	1
51	483227	Base 20"	1
52	962016	Screw, 10-32 x 3/8 Set	1
56	962019	Screw, 10-32 x 5/8 PHP	3

FM-17DS & FM-20DS FLOOR MACHINES - MOTOR & GEAR BOX ASSEMBLY

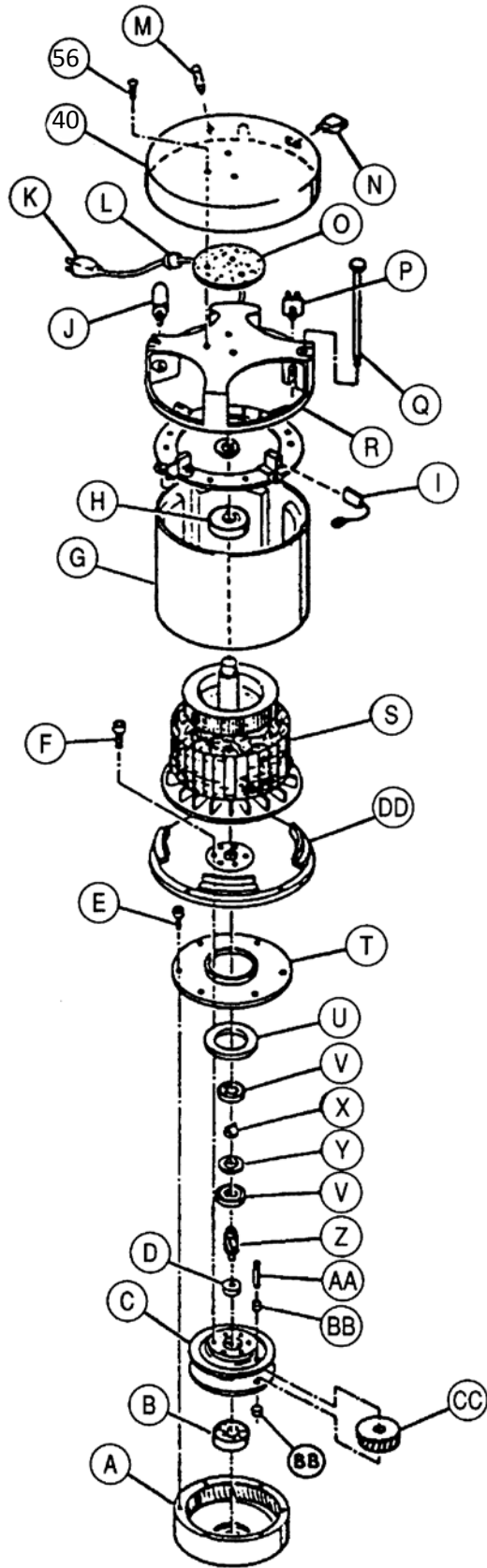

ITEM	PART NO.	DESCRIPTION	QTY.
	505265	Motor & Gear Assembly, 1.5hp, 115V	1
	505266	Motor & Gear Assembly, 1.5hp, 230V	1
A	504209	Housing, Ring Gear	1
B		Bearing, Motor Bottom	1
C	504208	Housing, 3 Idler Gear	1
D		Bearing, Lower Pinion	1
E	960016	Screw, Ring Gear Housing	6
F	960017	Screw, Planet Housing	6
G		Field/Shell Assembly	1
H	902003	Bearing, Motor Top	1
I	500903	Carbon Brush, 115V	4
	510901	Carbon Brush, 230V	4
J	911127	Speed Control, 115V	1
	911141	Speed Control, 230V	1
K	908024	Cord Assembly, Motor	1
L	508519	Strain Relief	1
M	505181	Light, Brush Indicator, 115V	1
	505182	Light, Brush Indicator, 230V	1
N	911115	Switch, Rocker, 20 Amp	1
O	509823	Washer, Felt	1
P	911048	Rectifier, Bridge, 115V	1
	911081	Rectifier, Bridge, 230V	1
Q	960018	Bolt, Motor Thru	2
R	502928	End Bell, Motor Top	1
S	500425	Armature Assembly, 115V	1
	500423	Armature Assembly, 230V	1
T	502317	Cover, Ring Gear	1
U	902015	Bearing	1
V	902005	Bearing, Upper Pinion	2
X	502460	Coupling, Motor	1
Y	508211	Spacer, Sleeve	1
Z	503510	Gear, Pinion	1
AA	507701	Shaft, Idler	3
BB	902016	Bearing, Needle	3
CC	503511	Gear, Idler	3
DD	502929	End Bell, Lower	1

WIRING DIAGRAM

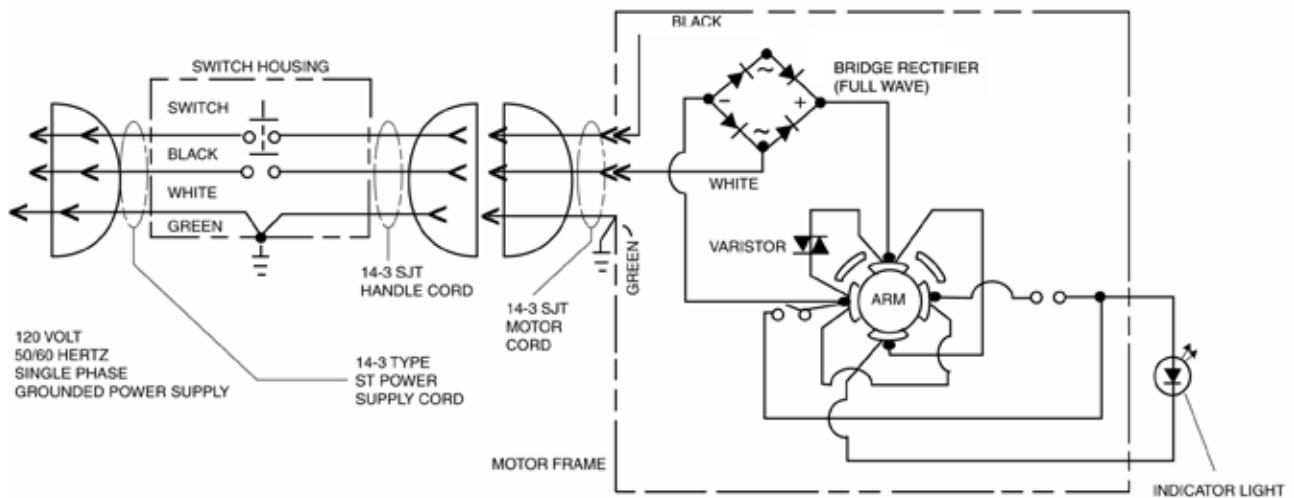

WARRANTY POLICY
FLOOR MACHINES, FM-17DS & FM-20DS

The **Pacific Floorcare FM-17DS & FM-20DS** floor machines have been manufactured, tested and inspected in accordance with specific engineering requirements and are **WARRANTED** to be free from defects in workmanship and materials as follows:

Three (3) years parts, One (1) year labor - DC motor and gear unit (excluding motor switches, rectifiers, carbon brushes and flex couplings which have a one (1) year warranty).

One (1) year parts and labor – All other components unless excluded below.

This warranty extends to the original user/purchaser and only when used, operated and maintained in accordance with **Pacific** Operating and Maintenance instructions.

This warranty does not ~~apply to~~ the following wear parts and accessories of the machine including:

<u>Part Number</u>	<u>Part Name</u>
502422	Cord Assembly
509781	Wheel
503711	Handle Grip
481202	Bumper, 17"
481203	Bumper, 20"

Nor does it apply to damage or failure caused by improper use, abuse or neglect. Warranty credit or replacement of return parts including motors, etc., is subject to incoming inspection of those items.

To secure repair under this warranty, the following procedure should be taken:

- The inoperative machine or warranted parts must be delivered to the authorized dealer with shipping and delivery charges prepaid. If unable to locate the Dealer, you may contact **Pacific** at the address listed herein for the location of the nearest **Pacific** repair center or agent or for other instructions pertaining to your warranty difficulty.
- Upon compliance with the above warranty procedure, all warranted repairs would be completed at no additional charge or cost to the user.
- Only **Pacific** or its authorized dealers and agents may make no charge warranty repairs on this product. All others do so at their own risk.

This warranty limits **Pacific** liability to the repair of the product and/or warranted parts replacement and does not include incidental or consequential damages arising from the use of a **Pacific** machine whether defective or not.

This warranty is in lieu of all other expressed or implied warranties and is extended to the original purchaser/user.



PACIFIC[™]
FLOORCARE

PURPOSE BUILT.[™]

2259 S. SHERIDAN DRIVE
MUSKEGON, MICHIGAN 49442-6252
800-968-1332
FAX 800-863-9536